

### Cable Layout:

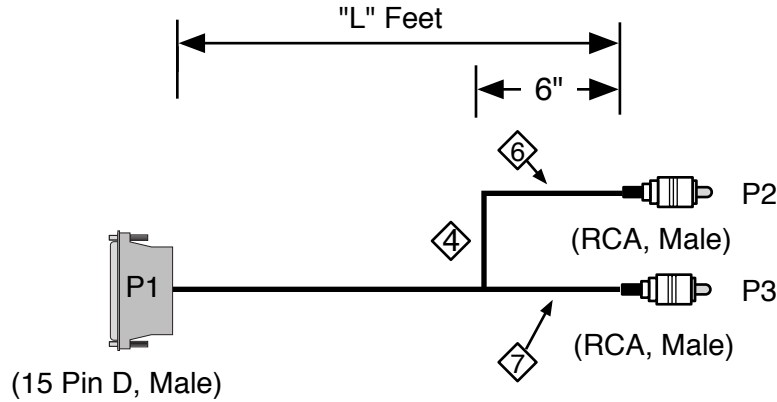

CA-D15M-Y-R2M-R2M-L-A\_02

### NOTES:

1. P1: D-Sub 15-pin male connector. Metal backshell with thumbscrews and strain relief.
2. P2 & P3: Switchcraft male RCA plugs (PN#: 3502A)
3. Use Canare MR202-2AT audio cable
4. Apply black flex braid to both legs after split.
5. Wire as shown. Float shield connections at RCA ends. Tie shields to chassis ground pin 8.
6. Apply label: "Iris Output"
7. Apply label: "Iris Input"

### Wiring Information: ⑤

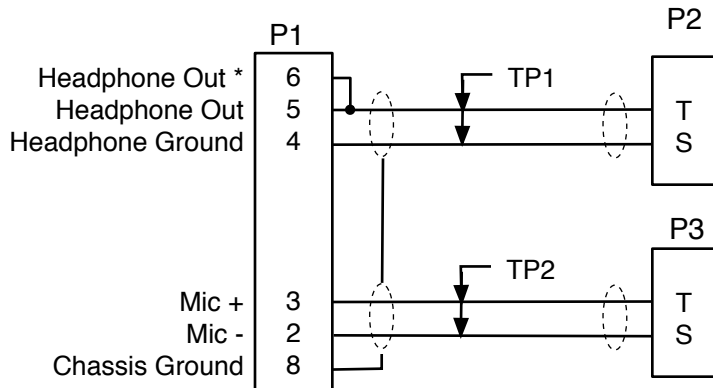

Rev	Date	Originator	Description
01	6-2-06	NAK	Original Release
02	4-20-09	CJA	Added Information Table

 <b>ADVANCED SIMULATION TECHNOLOGY inc.</b> 500A Huntmar Park Drive, Herndon, VA 20170 <a href="http://www.asti-usa.com">www.asti-usa.com</a>	
Cage Code	OVPW3
Title	Audio Cable
Dwg #	CA-D15M-Y-R2M-R2M-L-A_02
Sheet	1 of 1

Industry connector Sub Group	ASTi Part Number Sub Group	Source Device	ASTi Part Number	Current Revision Number	Description & Case Use	Special Notes
DB15	D15*	ACU, ACU2	CA-D15M-Y-R2M-R2M-L-A	02		