

⑤ Cable Layout:

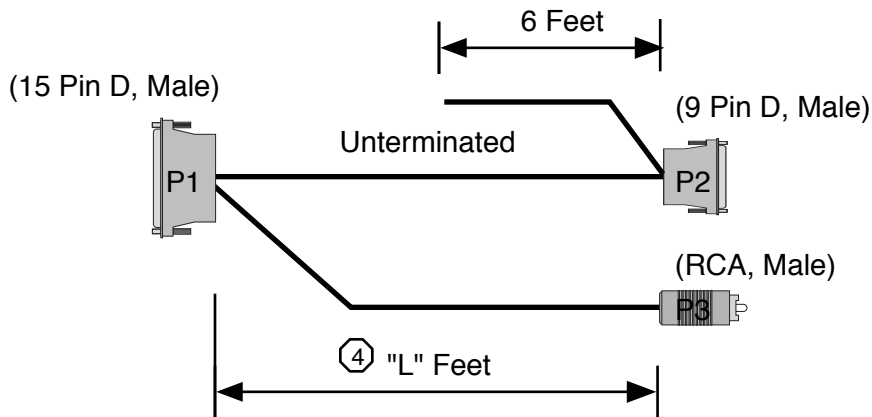

⑤ Wiring Information:

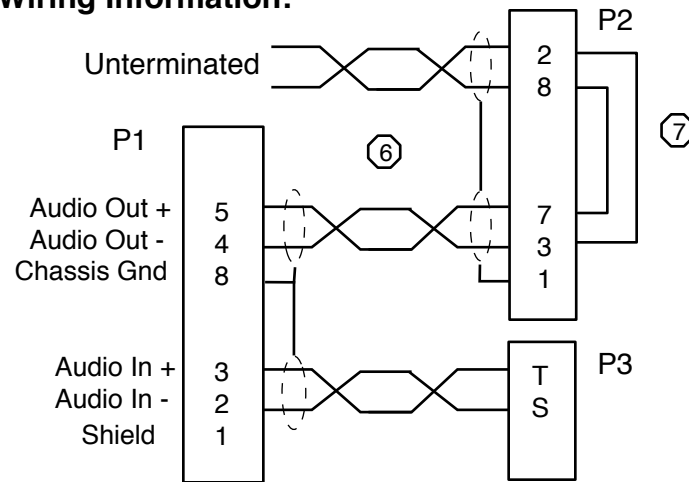

Parts List:

Item	Qty	Reference	P/N	Mfg	Description	Notes
1	1	P1	XXX-XXXX	XXXXXXX	15-pin Male D-shell	1
2	1	P2	XXX-XXXX	XXXXXXX	9-pin Male D-shell	1
3	1	P3	3502A	Switchcraft	RCA/Phono Plug	2
4	AR	-			Audio Cable	3
-	-	-				

Notes:

- ① Use high quality supplier such as AMP or equivalent.
- ② Use Switchcraft P/N 3502A or equivalent
- ③ Use low capacitance, shielded, twisted pair, high flex audio cable.
- ④ Cable length "L" defined by length field of part number ordered. Length applies to both cable legs.
- ⑤ Wiring and cable layout as shown.
- ⑥ Individually shielded twisted pair configuration as shown.
- ⑦ Add jumper wires to connect pins 2&3 and 7&8

Rev	Date	Originator	Description
01	5-5-04	JPM	original release
02	3-9-05	NAK	Corrected shield connections
03	4-20-09	CJA	Added Information Table

 ADVANCED SIMULATION TECHNOLOGY inc. 500A Huntmar Park Drive, Herndon, VA 20170 www.asti-usa.com	
Cage Code	OVSFW3
Title	Audio Cable, IRIS to DB9 Out & Phono In
Dwg #	CA-D15M-Y-R2M-D9M-UT-L-A_03
Sheet	1 of 1

Industry connector Sub Group	ASTi Part Number Sub Group	Source Device	ASTi Part Number	Current Revision Number	Description & Case Use	Special Notes
DB15	D15*	ACU, ACU2	CA-D15M-Y-R2M-D9M-UT-L-A	03		